

LET'S MAKE
ROOM FOR
PEOPLE

PRESSALIT®



INDIVO
HEIGHT ADJUSTABLE KITCHENS
FOR EVERYBODY

LET THE KITCHEN WORK FOR YOU

The kitchen is one of the most important rooms in any home. Much of family life takes place there, and it is one of those spaces where it truly matters that everybody can participate in activities and food preparation on equal terms.

However, people living with physical disabilities may find an ordinary kitchen with fixed countertops and cabinet units difficult to negotiate, accessing them in a wheelchair being particularly challenging. In this situation, a height adjustable kitchen solution can make all the difference.

WHAT IS A HEIGHT ADJUSTABLE KITCHEN?

A height adjustable kitchen from Pressalit consists of lifting units for fitting to the walls, on which are mounted countertops or cabinets. The lifting units will carry up to 330 lbs/150 kg and can be fitted with most commercially available kitchen furniture and appliances.

In addition to the wall mounted lifting units, the range includes free-standing lifting units, and by combining them it is possible to build a kitchen with lifting solutions wherever they are required.

WHY CHOOSE A HEIGHT ADJUSTABLE KITCHEN?

Most of us know the challenge of not being able to reach something on the top shelf in a cabinet. Imagine not being able to reach to stir the pot on your stove without burning yourself, or to get a glass off even the lowest shelf of the cabinet. This is the reality for many wheelchair users.

Fortunately, there are solutions to meet these challenges. A kitchen with a height adjustable countertop becomes accessible to a wheelchair user, one with a height adjustable hob or sink even more so. In such a kitchen, a seated person will be able to sit at the countertop at an ergonomically correct working height. In addition to this, height adjustable cabinets will allow the seated person to open cabinets and reach the contents themselves.

A height adjustable kitchen improves the daily workflow in the kitchen. It allows everybody to participate in food preparation and cooking, increasing independence and social interactions with the other occupants of the home.

ROOM FOR EVERYBODY - AT HOME AND IN HOMES

Pressalit INDIVO offers plenty of opportunity for every user. The INDIVO system is suitable for installation in private homes, as well as in settings with many disabled occupants. The ease of adjustment allows adaptation to individual needs at the push of a button, so both seated and standing users will be able to use the kitchen facilities to the best of their abilities.

This includes everybody in daily tasks and creates a community around mealtimes, leading to better quality of life for everybody.

MANUAL OR ELECTRIC ADJUSTMENT?

The INDIVO kitchen offers two different types of adjustment: either electrically powered or manual. In the case of electrical adjustment, all the lifters are adjusted by pressing a button in the countertop fascia, or buttons on a wired hand control. Each button controls a countertop or cabinet lifter, allowing easy adjustment up or down to the correct height and back again. In the manual version, operation is by crank handle, allowing the winding up or down of the countertop. Cabinet lifters are only available for electrical operation.

A kitchen with electrically powered height adjustment is ideal for situations with several users with varying needs. This makes it suitable for private homes with seated and standing users, as well as for nursing homes, teaching kitchens and similar facilities as well as in bars and restaurants.

A kitchen with manual height adjustment of the countertop is suitable for a kitchen where the height is set for long periods at a time and will rarely need adjusting. This might be in a private home or in sheltered housing where only one person uses the kitchen and the height will only need changing when that person's needs change or a new occupant moves into the home.

ABOUT HEIGHT ADJUSTABLE KITCHENS	PAGE	4-5
LIFTS FOR COUNTERTOP, WALLHUNG, ELECTRIC, WITH 2 LEGS	PAGE	6
LIFTS FOR COUNTERTOP, WALLHUNG, ELECTRIC, WITH 3 LEGS	PAGE	7
LIFTS FOR COUNTERTOP, WALLHUNG, MANUAL	PAGE	8
LIFTS FOR COUNTERTOP, FREE-STANDING, ELECTRIC	PAGE	9
LIFTS FOR COUNTERTOP, FREE-STANDING, MANUAL	PAGE	10
BRACKETS, WALLHUNG, MANUAL	PAGE	11
ACCESSORIES, LIFTS FOR COUNTERTOP	PAGE	12
ACCESSORIES AND OPERATION FOR LIFTS FOR COUNTERTOP	PAGE	13
LIFTS FOR WALL CABINETS	PAGE	14
ACCESSORIES FOR LIFTS FOR WALL CABINETS	PAGE	15
SAFETY SYSTEMS	PAGE	16-17



WORTH KEEPING IN MIND WHEN YOU DESIGN YOUR KITCHEN

We have all different needs, and if you have a physical limitation, it is important that your surroundings adjust to you - not the other way around. This is more easily achieved by having the right assistive aids to make the kitchen more accessible so everybody can participate in meal preparation and other activities in the kitchen.

There are many things to consider when attempting to ensure the best possible layout of a kitchen, - even more so when it needs to accommodate both seated and standing users. The means of operation should be chosen carefully to suit the users' abilities, be they partially sighted, with limited motor skills or cognitively challenged.

The first thing to ensure is space for a turning circle in the kitchen, so there is room for a wheelchair to manoeuvre. As a guide, allow for turning circles between 55.1"/140 cm and 82.7"/210 cm for a wheelchair although some equipment may need more space.

- 1 Drawers offer their contents up much more readily than shelves behind cabinet doors.
- 2 Countertops can be fitted to lifting units so the height of them can be adjusted as and when required. Pressalit INDIVO lifting units travel 11.8"/30 cm as standard, but can be made with less or more travel to order. This height adjustment applies to countertops whether or not they have sinks and/or stove built into them.
- 3 Safety first. With Pressalit INDIVO lifting units you can have safety bars fitted to the underside of the fascia to avoid any risk of injury from crushing and anticollision solutions that protect the things you keep under the countertop.
- 4 Cabinets fitted to a cabinet lifting unit can be adjusted down and forward to bring the contents within easy reach of any kitchen users. It is important that a safety plate be fitted to the underside to protect people from injury and things from damage.
- 5 The primary shelves in the fridge should be at a height that can be easily reached from a wheelchair, which usually means between 15.7"/40 cm and 55.1"/140 cm above the floor.

Remember that you can always ask Pressalit for advice on the layout of your kitchen, so you are certain to get the best possible solution for any specific needs.

- 6 Place the dishwasher in close proximity to the sink, - and choose a model with height adjustable baskets if possible.
- 7 Choose a shallow sink with a depth of no more than 3.9"-4.3"/10-11 cm. That will make it easier for a seated user to achieve an ergonomically correct position at the sink. And remember to make sure the underside of the sink is insulated against heat!
- 8 Fit the stove into a height adjustable countertop so seated users can reach the pots and pans comfortably. We recommend choosing an induction stove, but if one or more users are partially sighted, choose a hob with raised buttons/dials.
- 9 Consider placing the microwave oven in a height adjustable cabinet that can be lowered to meet the user.
- 10 Choose a cooker hood with hand control or with switches fitted within reach of the seated user.
- 11 Make sure the oven is at a height suitable for the user. Ovens with side-opening doors or with slide and hide doors are often better for wheelchair users, as will be those with telescopic rack, for safer handling of hot dishes.



Follow this advice to achieve a kitchen layout that considers the needs of both seated and standing users. You can also choose to add a freestanding dining table or countertop, which is adjustable from 26.6"/67.5 cm to 38.4"/97.5 cm in height just like the wall-mounted countertop lifters

LIFTS FOR COUNTERTOP, WALLHUNG, ELECTRIC, WITH 2 LEGS

Maximum load 220 lbs / 100 kg

INDIVO LIFT FOR COUNTERTOP 23.6" - 39.4"/600-1000 MM

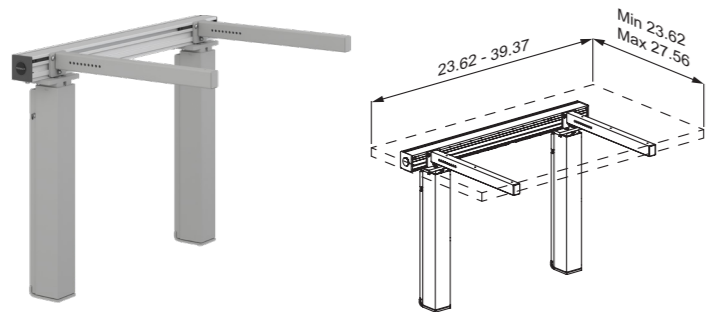

INDIVO lift for countertop, with two motors and control box. Max. load: 220 lbs/100 kg including the countertop. Incl. cross brace and two brackets.

Height adjustable up to 11.8"/300 mm with switch or wired remote control. For countertop length 23.6" - 39.4"/600-1000 mm. Please indicate length and depth of countertop when ordering. Excl. mounting kit.

RK1810202 Gray (RAL 9006)

INDIVO LIFT FOR COUNTERTOP 39.5" - 55.1"/1001-1400 MM

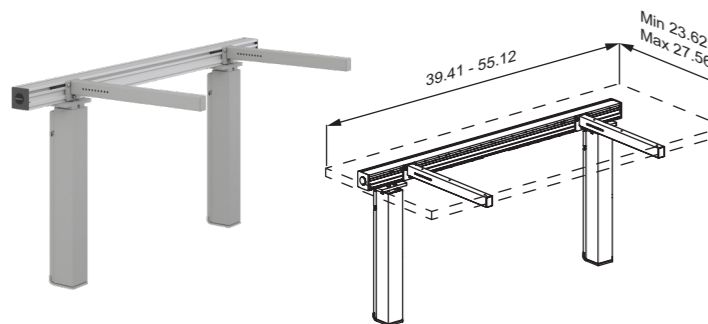

INDIVO lift for countertop, with two motors and control box. Max. load: 220 lbs/100 kg including the countertop. Incl. cross brace and two brackets.

Height adjustable up to 11.8"/300 mm with switch or wired remote control. For countertop length 39.5" - 55.1"/1001-1400 mm. Please indicate length and depth of countertop when ordering. Excl. mounting kit.

RK1811202 Gray (RAL 9006)

INDIVO LIFT FOR COUNTERTOP 55.2" - 78.7"/1401-2000 MM

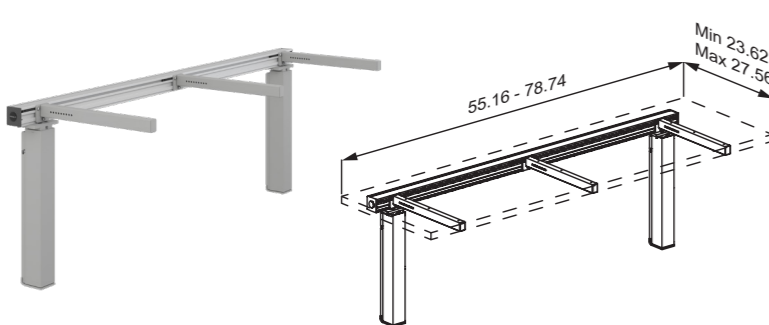

INDIVO lift for countertop, with two motors and control box. Max. load: 220 lbs/100 kg including the countertop. Incl. cross brace and three brackets.

Height adjustable up to 11.8"/300 mm with switch or wired remote control. For countertop length 55.2" - 78.7"/1401-2000 mm. Please indicate length and depth of countertop when ordering. Excl. mounting kit.

RK1812202 Gray (RAL 9006)

INDIVO LIFT FOR COUNTERTOP 78.8" - 94.5"/2001-2400 MM

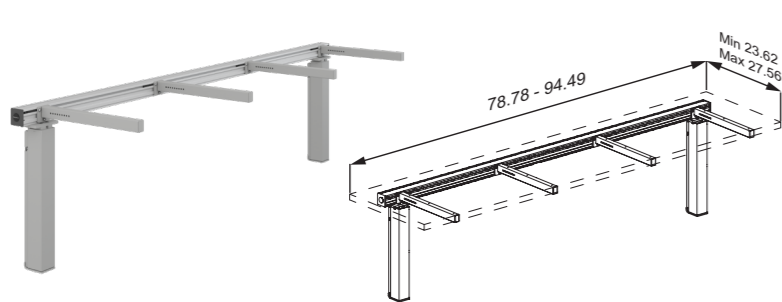

INDIVO lift for countertop, with two motors and control box. Max. load: 220 lbs/100 kg including the countertop. Incl. cross brace and four brackets.

Height adjustable up to 11.8"/300 mm with switch or wired remote control. For countertop length 78.8" - 94.5"/2001-2400 mm. Please indicate length and depth of countertop when ordering. Excl. mounting kit.

RK1813202 Gray (RAL 9006)

INDIVO LIFT FOR COUNTERTOP 94.6" - 118.1"/2401-3000 MM

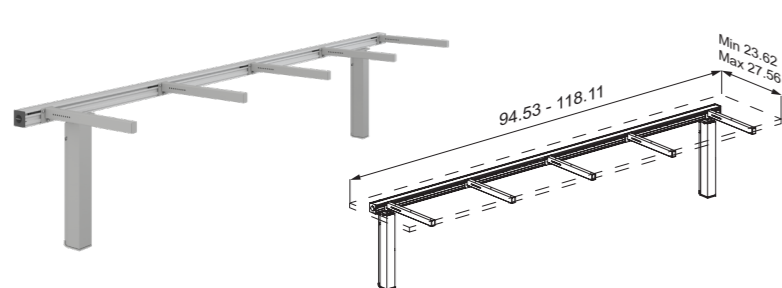

INDIVO lift for countertop, with two motors and control box. Max. load: 220 lbs/100 kg including the countertop. Incl. cross brace and five brackets.

Height adjustable up to 11.8"/300 mm with switch or wired remote control. For countertop length 94.6" - 118.1"/2401-3000 mm. Please indicate length and depth of countertop when ordering. Excl. mounting kit.

RK1814202 Gray (RAL 9006)

LIFTS FOR COUNTERTOP, WALLHUNG, ELECTRIC, WITH 3 LEGS

Maximum load 330 lbs / 150 kg

INDIVO LIFT FOR COUNTERTOP 23.6" - 39.4"/600-1000 MM

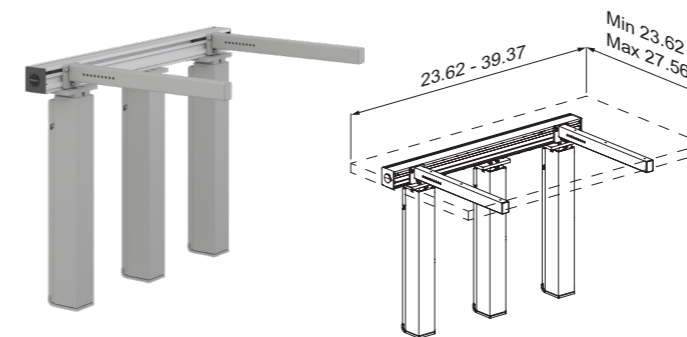

INDIVO lift for countertop, with three motors and control box. Max. load: 330 lbs/150 kg including the countertop. Incl. cross brace and two brackets.

Height adjustable up to 11.8"/300 mm with switch or wired remote control. For countertop length 23.6" - 39.4"/600-1000 mm. Please indicate length and depth of countertop when ordering. Excl. mounting kit.

RK1850202 Gray (RAL 9006)

INDIVO LIFT FOR COUNTERTOP 39.5" - 55.1"/1001-1400 MM

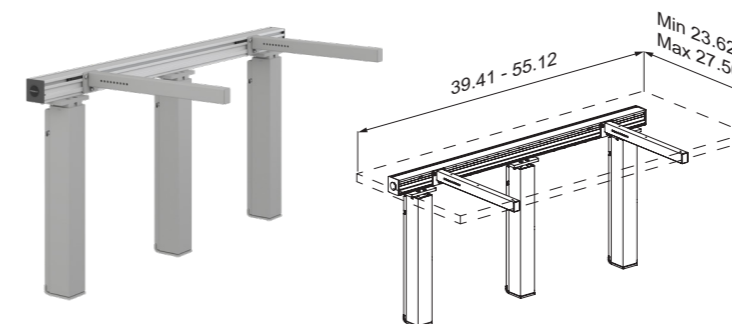

INDIVO lift for countertop, with three motors and control box. Max. load: 330 lbs/150 kg including the countertop. Incl. cross brace and two brackets.

Height adjustable up to 11.8"/300 mm with switch or wired remote control. For countertop length 39.5" - 55.1"/1001-1400 mm. Please indicate length and depth of countertop when ordering. Excl. mounting kit.

RK1851202 Gray (RAL 9006)

INDIVO LIFT FOR COUNTERTOP 55.2" - 78.7"/1401-2000 MM

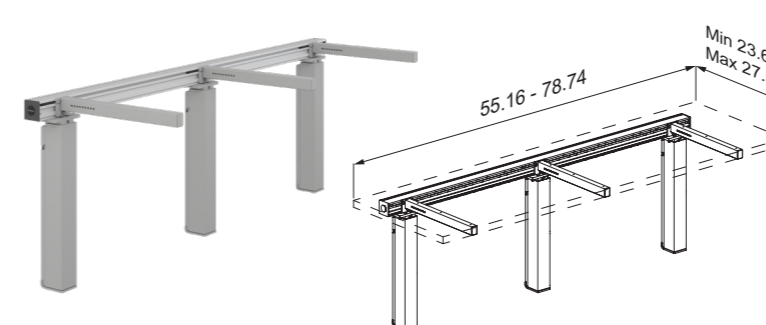

INDIVO lift for countertop, with three motors and control box. Max. load: 330 lbs/150 kg including the countertop. Incl. cross brace and three brackets.

Height adjustable up to 11.8"/300 mm with switch or wired remote control. For countertop length 55.2" - 78.7"/1401-2000 mm. Please indicate length and depth of countertop when ordering. Excl. mounting kit.

RK1852202 Gray (RAL 9006)

INDIVO LIFT FOR COUNTERTOP 78.8" - 94.5"/2001-2400 MM

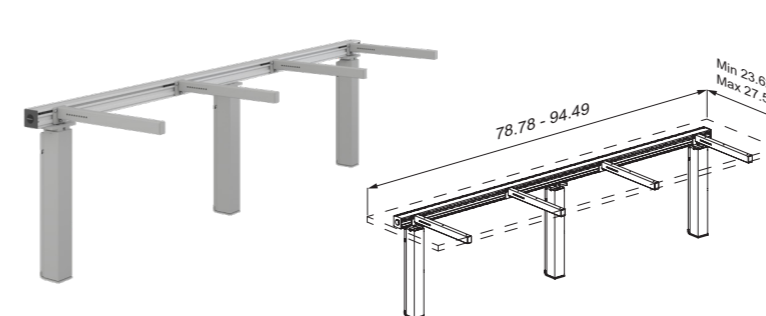

INDIVO lift for countertop, with three motors and control box. Max. load: 330 lbs/150 kg including the countertop. Incl. cross brace and four brackets.

Height adjustable up to 11.8"/300 mm with switch or wired remote control. For countertop length 78.8" - 94.5"/2001-2400 mm. Please indicate length and depth of countertop when ordering. Excl. mounting kit.

RK1853202 Gray (RAL 9006)

INDIVO LIFT FOR COUNTERTOP 94.6" - 118.1"/2401-3000 MM

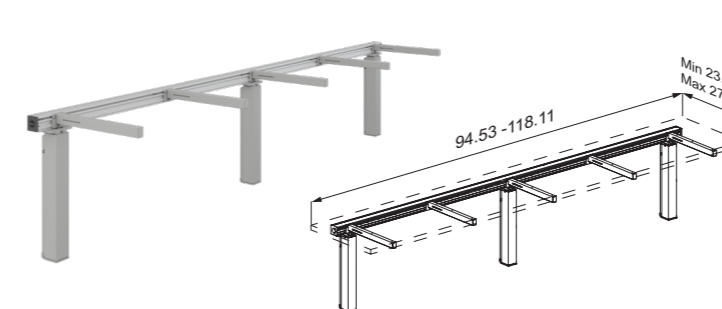

INDIVO lift for countertop, with three motors and control box. Max. load: 330 lbs/150 kg including the countertop. Incl. cross brace and five brackets.

Height adjustable up to 11.8"/300 mm with switch or wired remote control. For countertop length 94.6" - 118.1"/2401-3000 mm. Please indicate length and depth of countertop when ordering. Excl. mounting kit.

RK1854202 Gray (RAL 9006)

LIFTS FOR COUNTERTOP, WALLHUNG, MANUAL

Maximum load 220 lbs / 100 kg

LIFT FOR COUNTERTOP, MANUALLY HEIGHT ADJUSTABLE

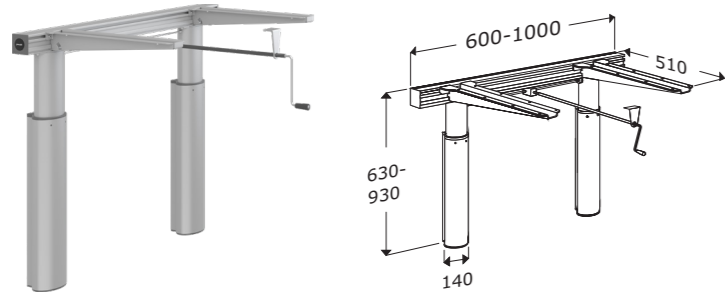

Manual lift for countertop.
Lift for countertop, with a crank handle.
Including 2 brackets. Lengths from 23.6"-39.4"/600-1000 mm.
Height adjustable 11.8"/300 mm.

Incl. mounting kit for brick wall.
Please state desired length when ordering

RK1110

LIFT FOR COUNTERTOP, MANUALLY HEIGHT ADJUSTABLE

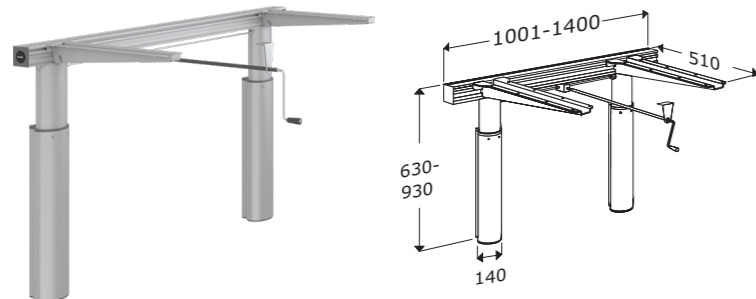

Manual lift for countertop.
Lift for countertop, with a crank handle.
Including 2 brackets. Lengths from 39.4"-55.1"/1001-1400 mm.
Height adjustable 11.8"/300 mm.

Incl. mounting kit for brick wall.
Please state desired length when ordering

RK1111

LIFT FOR COUNTERTOP, MANUALLY HEIGHT ADJUSTABLE

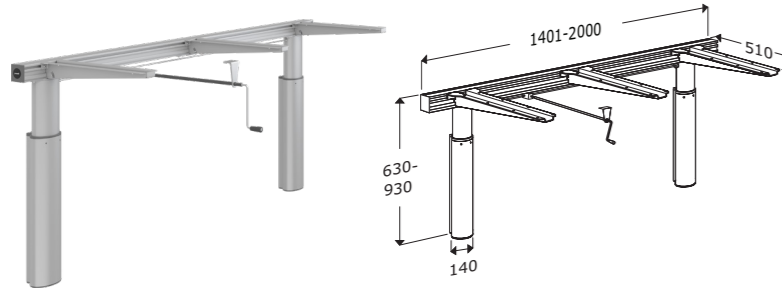

Manual lift for countertop.
Lift for countertop, with a crank handle.
Including 3 brackets. Lengths from 55.2"-78.7"/1401-2000 mm.
Height adjustable 11.8"/300 mm.

Incl. mounting kit for brick wall.
Please state desired length when ordering

RK1112

LIFT FOR COUNTERTOP, MANUALLY HEIGHT ADJUSTABLE

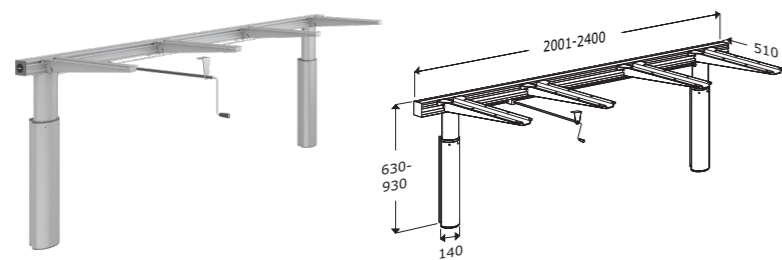

Manual lift for countertop.
Lift for countertop, with a crank handle.
Including 4 brackets. Lengths from 78.8"-94.5"/2001-2400 mm.
Height adjustable 11.8"/300 mm.

Incl. mounting kit for brick wall.
Please state desired length when ordering

RK1113

LIFT FOR COUNTERTOP, MANUALLY HEIGHT ADJUSTABLE

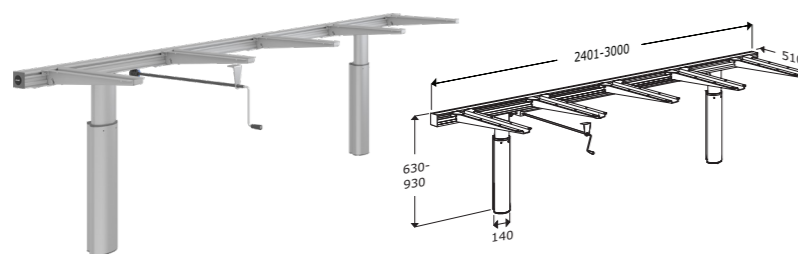

Manual lift for countertop.
Lift for countertop, with a crank handle.
Including 5 brackets. Lengths from 94.5"-118.1"/2401-3000 mm.
Height adjustable 11.8"/300 mm.

Incl. mounting kit for brick wall.
Please state desired length when ordering

RK1114

LIFTS FOR COUNTERTOP, FREESTANDING, ELECTRIC

Maximum load 220 lbs / 100 kg

LIFT FOR COUNTERTOP, ELECTRICALLY HEIGHT ADJUSTABLE

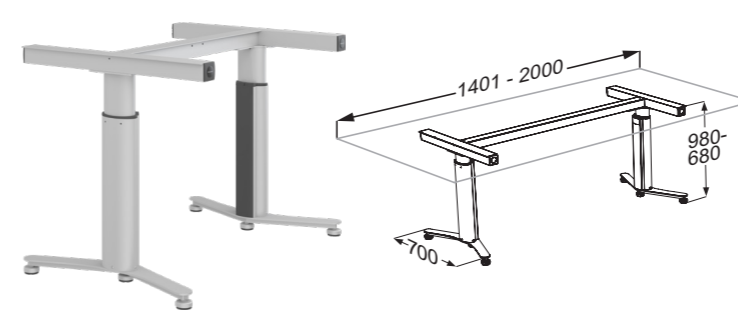

Electric lift for freestanding countertop.
For countertops from 55.1" - 78.7"/1400 - 2000 mm.

Height adjustable 11.8"/300 mm. Including 2 telescopic legs, longitudinal and cross braces and switch.

Pressalit recommends overhang of 7.9"/200 mm at either end to allow ease of approach in wheel-chair.
Please state desired length when ordering.

RK1081-93

LIFT FOR COUNTERTOP, ELECTRICALLY HEIGHT ADJUSTABLE

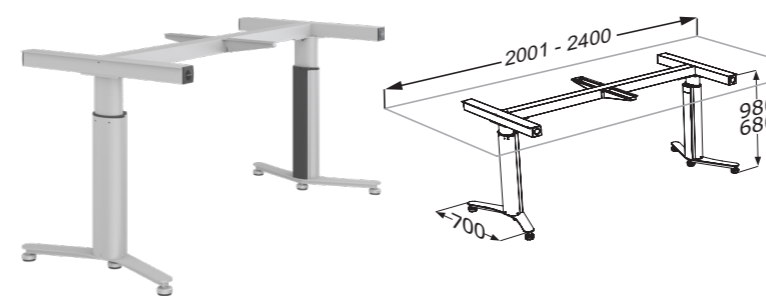

Electric lift for freestanding countertop.
For countertops from 78.8" - 94.5"/2001 - 2400 mm.

Height adjustable 11.8"/300 mm. Including 2 telescopic legs, brackets, longitudinal and cross braces and switch.

Pressalit recommends overhang of 15.8"/400 mm at either end of countertop to allow for ease of approach in wheel-chair. Please state desired length when ordering.

RK1082-93

LIFT FOR COUNTERTOP, ELECTRICALLY HEIGHT ADJUSTABLE

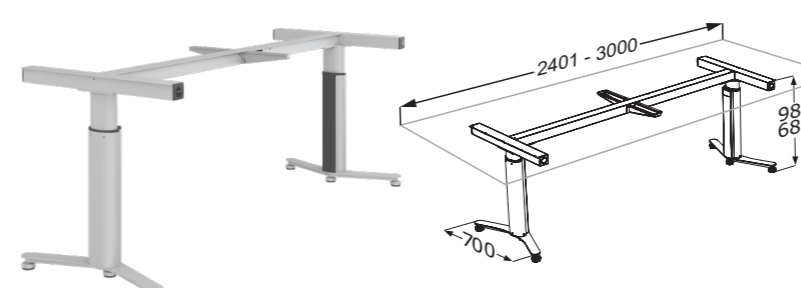

Electric lift for freestanding countertop.
For countertops from 94.5" - 118.1"/2401 - 3000 mm.

Height adjustable 11.8"/300 mm. Including 2 telescopic legs, brackets, longitudinal and cross braces and switch.

Pressalit recommends overhang of 15.8"/400 mm at either end of countertop to allow for ease of approach in wheel-chair. Please state desired length when ordering.

RK1083-93

LIFTS FOR COUNTERTOP, FREESTANDING, MANUAL

Maximum load 220 lbs / 100 kg

LIFT FOR COUNTERTOP, MANUALLY HEIGHT ADJUSTABLE

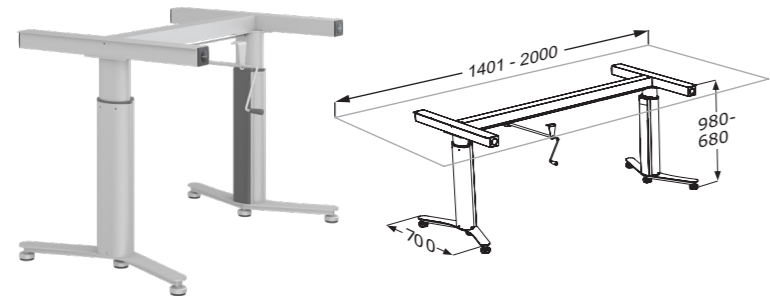

Manual lift for freestanding countertop. For countertops from 55.1" - 78.7"/1400 - 2000 mm. Height adjustable 11.8"/300 mm. Including 2 telescopic legs, longitudinal and cross braces and crank handle.

Pressalit recommends overhang of 7.9"/200 mm at either end to allow ease of approach in wheel-chair. Please state desired length when ordering.

RK1181

LIFT FOR COUNTERTOP, MANUALLY HEIGHT ADJUSTABLE

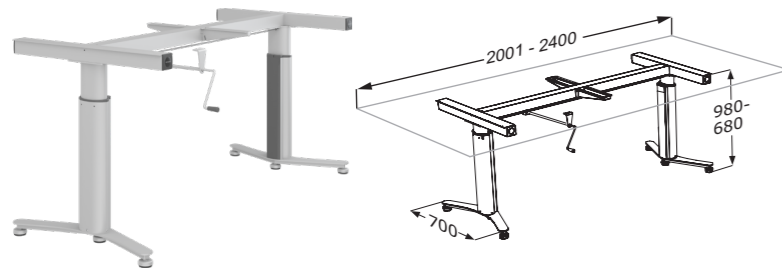

Manual lift for freestanding countertop. For countertops from 78.8" - 94.5"/2001 - 2400 mm. Height adjustable 11.8"/300 mm. Including 2 telescopic legs, brackets, longitudinal and cross braces and crank handle.

Pressalit recommends overhang of 15.8"/400 mm at either end of countertop to allow for ease of approach in wheel-chair. Please state desired length when ordering.

RK1182

LIFT FOR COUNTERTOP, MANUALLY HEIGHT ADJUSTABLE

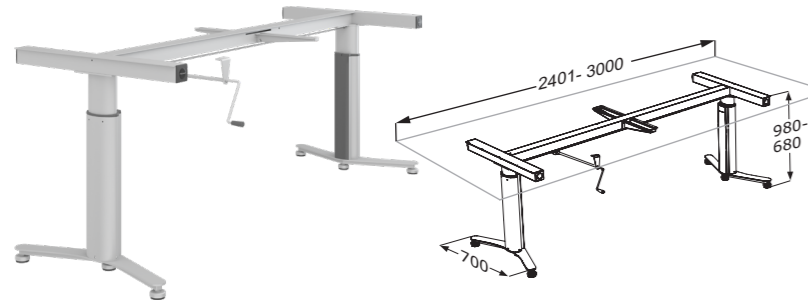

Manual lift for freestanding countertop. For countertops from 94.5" - 118.1"/2401 - 3000 mm. Height adjustable 11.8"/300 mm. Including 2 telescopic legs, brackets, longitudinal and cross braces and crank handle.

Pressalit recommends overhang of 15.8"/400 mm at either end of countertop to allow for ease of approach in wheel-chair. Please state desired length when ordering.

RK1183

BRACKETS, WALLHUNG, MANUAL

INDIVO BRACKET

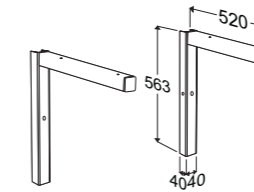

Bracket for countertop 20.5"x22.2"x1.6"/520x563x40 mm.

Including 2 wall fittings and 2 carrying brackets.

Height adjustable 9.8"/250 mm.

RK1100

INDIVO BRACKET

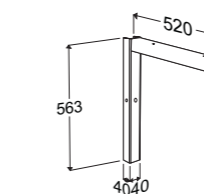

Bracket for countertop 20.5"x22.2"x1.6"/520x563x40 mm.

Including 1 wall fitting and 1 carrying bracket.

Height adjustable 9.8"/250 mm.

RK1101

CRANK HANDLE OPERATED LIFTING JACK

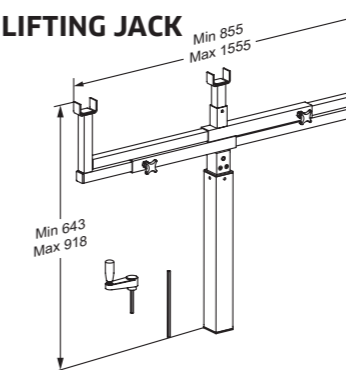

Crank-operated raiser for fitting with brackets for countertop RK1100/RK1101.

Height: 25.3"-36.1"/643-918 mm.
Width: 33.7"-61.2"/855-1555 mm.

Can adjust the height of the countertop with up to 9.8"/250 mm."

RK1145

INDIVO REINFORCEMENT BRACKET



Reinforcement bracket. Extra bracket for reinforcing heavy countertops or countertops including sink or hob. Only for wall-mounted INDIVO lifts.

RK1340202 Gray (RAL 9006)

FLEXIBLE FEED AND WASTE SYSTEM 19.7" /9.8"-27.6"/500/250-700 MM

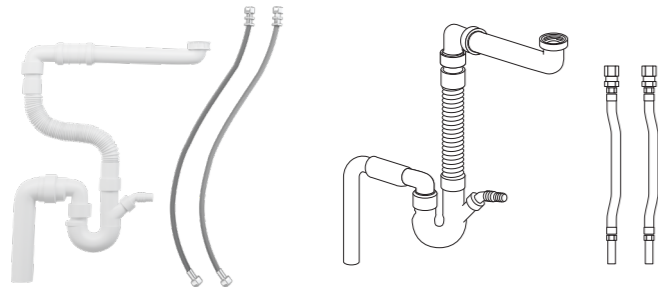

Flexible feed/waste system. Feed pipes: 19.7"/500 mm, waste pipe: 9.8"-27.6"/250-700 mm, diameter 1.6"/40 mm. The flexible waste pipe is very resistant to both chemical and physical influences.

It is flame retardant and withstands temperatures from -30 ° C to +110 ° C.

RK9061

INSTALLATION COVER

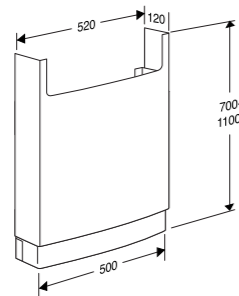

Installation cover 27.6"-39.4"x4.4"/700-100x520x120 mm.

Covers and protects flexible feed/waste system.

RK1043 Gray
RK1043000 White

CABLE TRAY, 78.7"/2000 MM

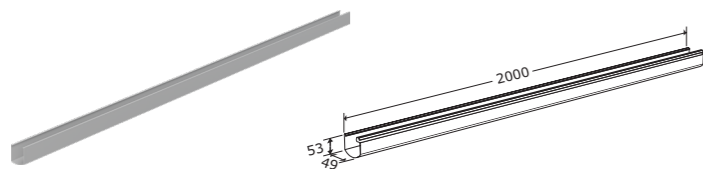

Cable tray, 78.7"/2000 mm, for wall-mounted INDIVO lift for countertop.

RK1050

INDIVO STABILISING FOOT



Stabilizing foot, 1 pc. For INDIVO lift for countertop. Provides extra support in case the wall is not sufficiently strong.

RK1342000 White
RK1342202 Gray (RAL 9006)

BRACKETS FOR FITTING OF FASCIA



Brackets for fitting of fascia, 4 pieces. The recommended number is 4 for each running meter.

RK1044

INDIVO BRACKET FOR FITTING OF COVER PLATE



Bracket for fitting of cover plate. 1 pc. For INDIVO lift for worktop.

RK1344

WIRED REMOTE CONTROL, CABLE LENGTH 63"/1600 MM

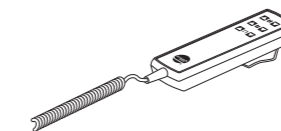

Wired hand control, cable length 63"/1600 mm.

Can be used as a supplement for or instead of switch for fascia. Only for wall-mounted INDIVO lifts.

RK1045

SWITCH FOR FASCIA, CIRCULAR



Switch for fascia, circular. For INDIVO lift for countertop. RK1354 Black

Switch for fascia, circular. For INDIVO lift for wall cabinets. RK1355 Silver

SWITCH FOR FASCIA, OVAL

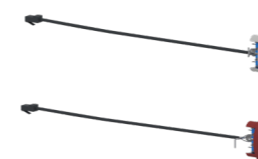

Switch for fascia, oval. For INDIVO lift for countertop. RK1054 Aluminium

Switch for fascia, oval. For INDIVO lift for wall cabinets. RK1055 Red

COLLAPSIBLE CRANK HANDLE

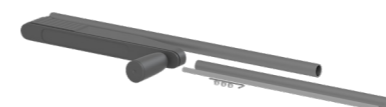

Collapsible crank handle. Crank handle for countertop without fascia. Can be folded away under countertop. Not visible below countertop.

RK1041

LIFTS FOR WALL CABINETS

INDIVO LIFT FOR WALL CABINETS 15.7"-47.2"/400-1200 MM

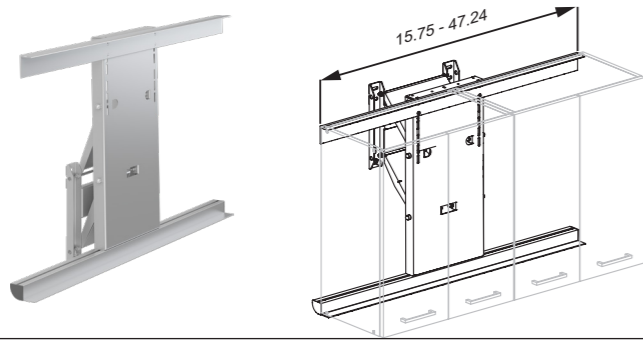

INDIVO lift for wall cupboards, with one motor and control box. Max. load: 240 lbs/110 kg including the cabinet. Height adjustable 16.9"/430 mm with switches or wired remote control. When height adjusting downward, the lift will also move 7.1"/180 mm towards the user. For wall cabinets width 15.7"-47.2"/400-1200 mm.

Please indicate height, width and depth of wall cabinets when ordering. Excl. mounting kit.

RK1820

INDIVO LIFT FOR WALL CABINETS 47.3"-94.5"/1201-2400 MM

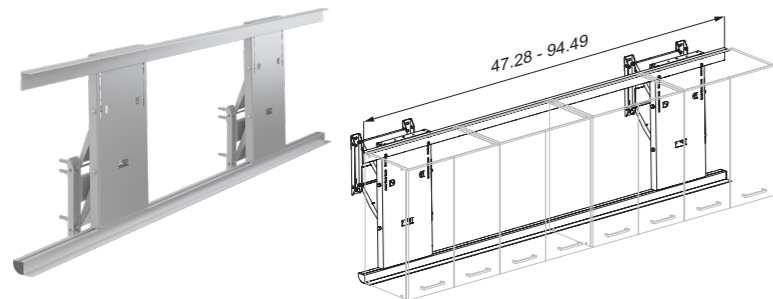

INDIVO lift for wall cupboards, with two motors and control box. Max. load: 485 lbs/220 kg including the cabinets. Height adjustable 16.9"/430 mm with switches or wired remote control. When height adjusting downward, the lift will also move 7.1"/180 mm towards the user. For wall cabinets width 47.3"-94.5"/1201-2400 mm.

Please indicate height, width and depth of wall cabinets when ordering. Excl. mounting kit.

RK1821

ADJUSTABLE BRACKETS

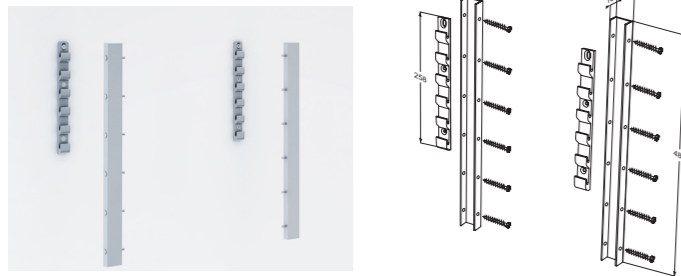

Brackets for wall cabinets, height adjustable by 18.1"/460 mm. Incl. 2 wall fittings and 2 brackets.

Can be fitted with wall cabinets that are minimum 19.7"/500 mm tall.

RK1120

ACCESSORIES FOR LIFTS FOR WALL CABINETS

WIRED REMOTE CONTROL, CABLE LENGTH 63"/1600 MM

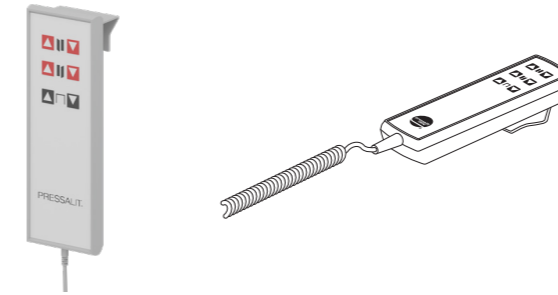

Wired hand control, cable length 63"/1600 mm. Can be used as a supplement for or instead of switch for fascia. Only for wall-mounted INDIVO lifts.

RK1045

CABLE TRAY, 78.7"/2000 MM

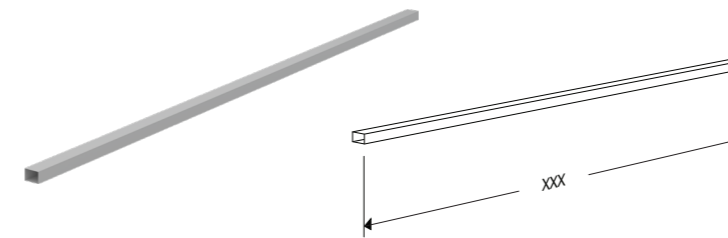

Cable tray, 78.7"/2000 mm, white, for INDIVO lift for wall cabinets

RK1051000 White

EXTENSION FITTING, 15.7"-47.2"/400-1200 MM, 1 PC

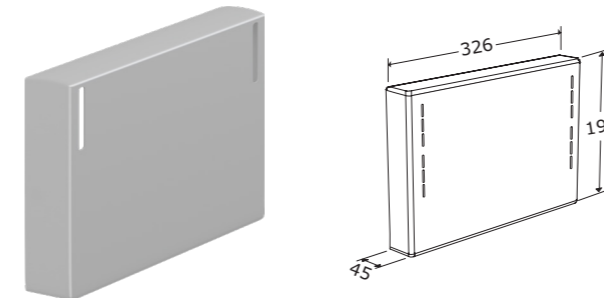

Extension fitting, 15.7"-47.2"/400-1200 mm, 1 pc. For installing cabinets higher than 27.7"/704 mm.

12.8"x7.7"x1.8"/326x196x45 mm.

For INDIVO lift for wall cupboards. Please indicate height of wall cupboards when ordering.

RK1065

EXTENSION FITTINGS, 15.7"-47.2"/400-1200 MM, 2 PCS

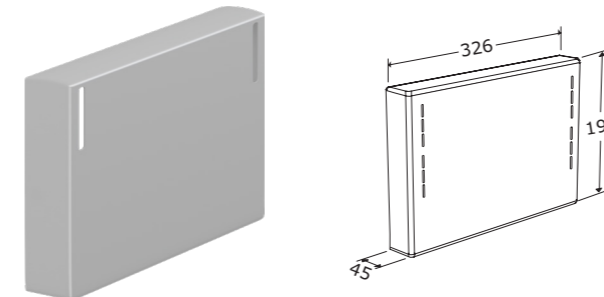

Extension fitting, 15.7"-47.2"/400-1200 mm, 2 pcs. For installing cabinets higher than 27.7"/704 mm.

12.8"x7.7"x1.8"/326x196x45 mm.

For INDIVO lift for wall cupboards. Please indicate height of wall cupboards when ordering.

RK1066

SAFETY BAR

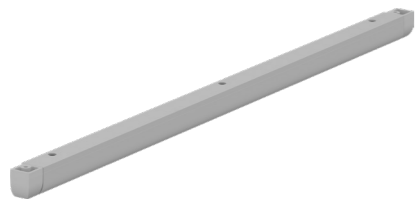

For INDIVO lift for countertop. Stops the downward movement of the countertop when resistance is felt and raises it 0.4"/10 mm. Please indicate length and depth of countertop when ordering.

- RK1397 Short side, length up to 27.6"/700 mm
- RK1390 Long side, 27.6"-39.4"/701-1000 mm
- RK1391 Long side, 39.5"-55.1"/1001-1400 mm
- RK1392 Long side, 55.2"-78.7"/1401-2000 mm
- RK1393 Long side, 78.8"-94.5"/2001-2400 mm
- RK1394 Long side, 94.6"-118.1"/2401-3000 mm

SAFETY PLATE

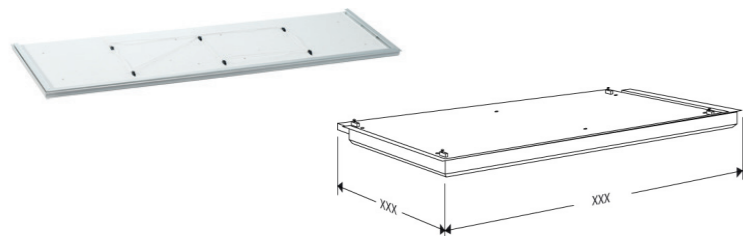

For INDIVO lift for wall cabinets. Stops the downward movement of the cabinet when resistance is felt and raises it 0.4"/10 mm. Please indicate width and depth of wall cabinets when ordering.

- RK1031 15.7"-47.2"/400-1200 mm
- RK1032 47.3" - 94.5"/1201-2400 mm

INTERCONNECTION OF SAFETY RK1770

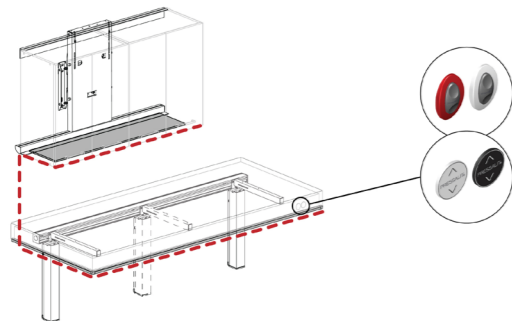

Interconnection of safety RK1770.
For interconnection of:
- Safety bars for countertop
- One safety plate for wall cabinets.

For all types of switch. Safety bars and safety plates to be ordered separately.

RK1770

INTERCONNECTION OF SAFETY RK1772

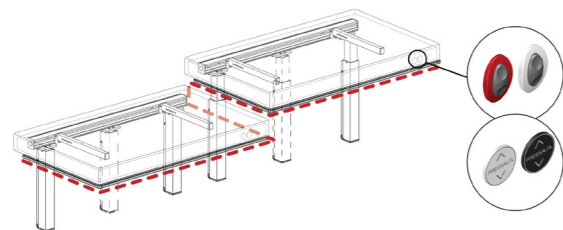

Interconnection of safety RK1772.
For interconnection of:
- Safety bars for countertop
- Two countertop lifts placed next to each other

For all types of switch. Safety bars and safety plates to be ordered separately.

RK1772

INTERCONNECTION OF SAFETY RK1774

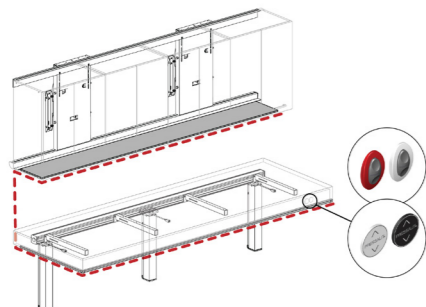

Interconnection of safety RK1774.
For interconnection of:-
- Safety bars for countertop
- One safety plate for wall cabinets.

For all types of switch. Safety bars and safety plates to be ordered separately.

RK1774

INTERCONNECTION OF SAFETY RK1771

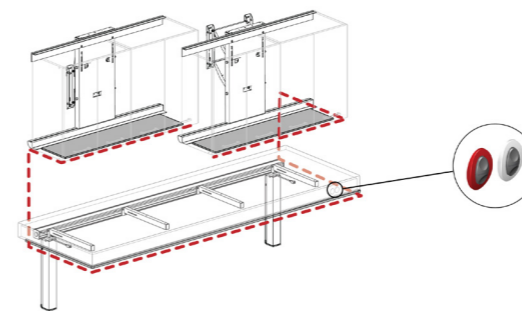

Interconnection of safety RK1771.
For interconnection of:
- Safety bars for countertop
- Two safety plates for wall cabinets.

For oval switch. Safety bars and safety plates to be ordered separately.

RK1771

INTERCONNECTION OF SAFETY RK1775

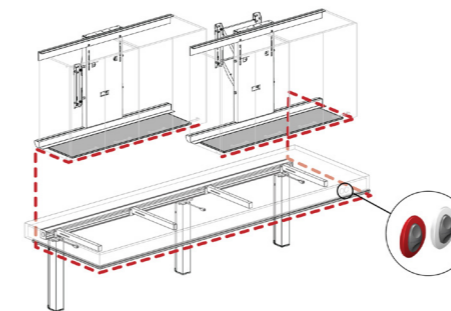

Interconnection of safety RK1775.
For interconnection of:
- Safety bars for countertop
- Two safety plates for wall cabinets.

For oval switch. Safety bars and safety plates to be ordered separately.

RK1775

INTERCONNECTION OF SAFETY RK1773

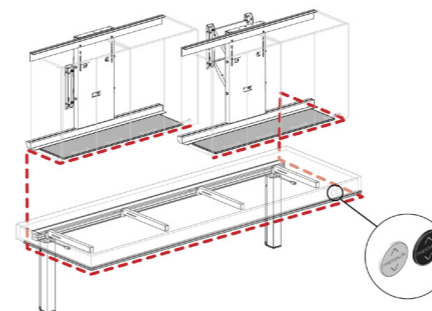

Interconnection of safety RK1773.
For interconnection of:
- Safety bars for countertop
- Two safety plates for wall cabinets.

For circular switch. Safety bars and safety plates to be ordered separately.

RK1773

INTERCONNECTION OF SAFETY RK1776

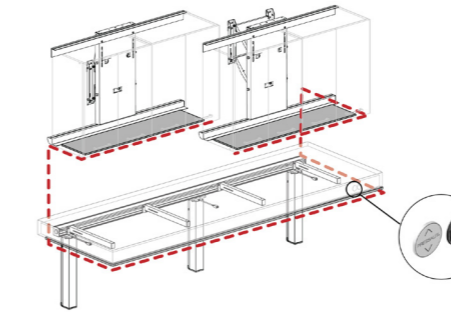

Interconnection of safety RK1776.
For interconnection of:
- Safety bars for countertop
- Two safety plates for wall cabinets.

For circular switch. Safety bars and safety plates to be ordered separately.

RK1776



LET'S MAKE
ROOM FOR
PEOPLE

PRESSALIT®

Pressalit A/S

Pressalitvej 1
8680 Ry
Denmark
T: +45 8788 8788
F: +45 8788 8789
pressalit@pressalit.com

Pressalit Inc.

2230 Stafford Road, Ste 115
Plainfield, Indiana 46168 USA
T: +1 317 494 2889
us@pressalit.com

Pressalit.com

PREMIUM BATHROOM SOLUTIONS SINCE 1954

Pressalit A/S is a Danish privately owned company with production facilities in Ry, Denmark. Since 1954, we have been designing and producing toilet seats of the highest quality. And since 1975, Pressalit has also been developing accessible bathrooms and height adjustable kitchens for people with reduced mobility. This has made us one of the world's leading manufacturers of premium bathroom solutions. High quality, flawless design and reliable functionality are the core features of our wide range of products.

PRESSALIT SUPPORTS UNITED NATIONS GLOBAL GOALS



Pressalit's Environmental and Quality Management Systems are certified by LRQA

Subject to changes in the product range, technical changes and printing errors.